

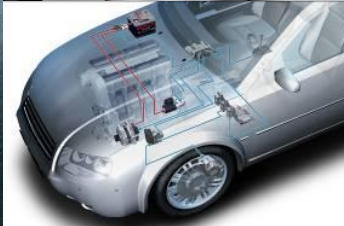

SupplyOn Implementation at Bosch China

Bin Huang, 6th of May 2010, Munich



Structure of the Bosch Group

Bosch Group
Sales: 38.2 billion euros¹⁾
Associates on Jan. 1, 2010:
270,687

Automotive Technology

Sales: 21.8 billion euros
Share of total sales: 57%



Industrial Technology

Sales: 5.0 billion euros
Share of total sales: 13%



Consumer Goods & Building Technology

Sales: 11.4 billion euros
Share of total sales: 30%



¹⁾ Including other activities



BOSCH

About Bosch in China

- 
- **47 legal entities** in China
 - 1 Investment Holding Company (Shanghai)
 - 34 Wholly-Foreign-Owned-Enterprises
 - 12 Joint Ventures
 - 2009 consolidated sales: **27.4 billion CNY** (2.9 billion EUR), **21 % growth** compared to 2008
 - **2.2 billion CNY** (231 million EUR) investment in 2008*
 - **21,200 employees** in China*; approx. 1,000 new employees in 2009

* Consolidated companies



BOSCH

Automotive Technology

Automotive Electronics

Car Multimedia

Gasoline Systems³⁾

Diesel Systems²⁾

Starter Motors
and Generators

Chassis Systems Brakes

Chassis Systems Control

Electrical Drives

Steering Systems¹⁾

Automotive Aftermarket

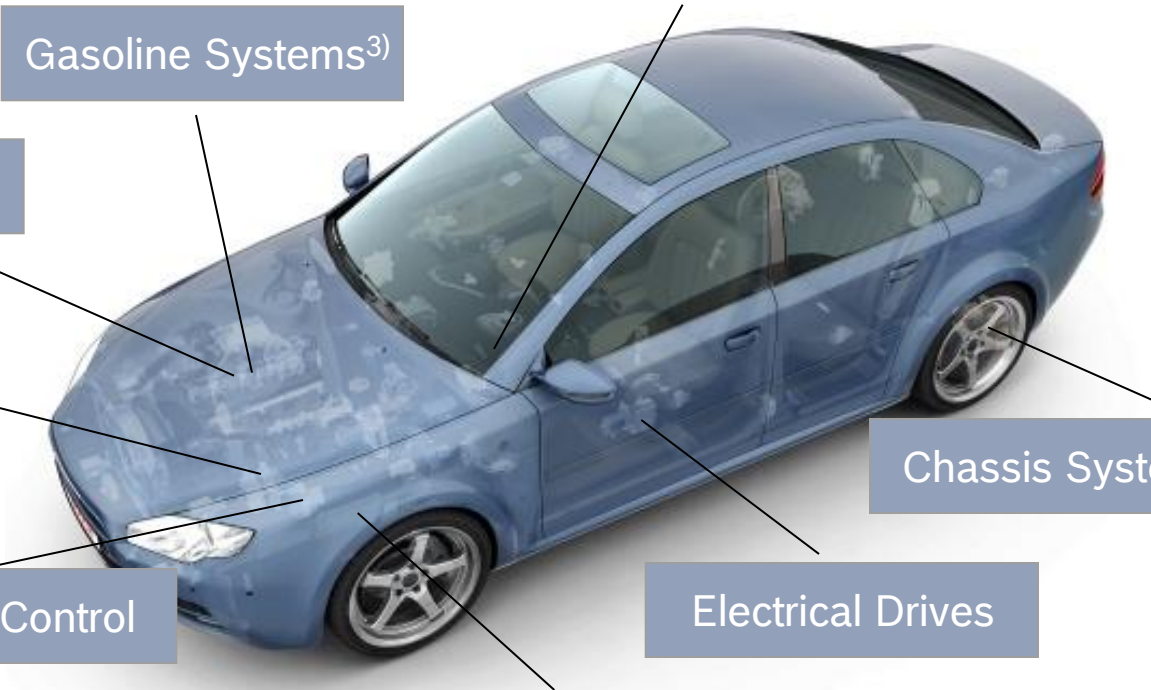

¹⁾ZF Lenksysteme GmbH (50% Bosch-owned)

²⁾Bosch Automotive Diesel Systems Co., Ltd. (67% Bosch-owned)

³⁾United Automotive Electronic System Co., Ltd. (51% Bosch-owned)



BOSCH

Industrial Technology

Drive and Control Technology



Electric drives and controls, hydraulics, assembly and linear-motion technology, pneumatics

Packaging Technology



Packaging machines and lines for the confectionery, food, and pharmaceuticals industries

Solar Energy*



Solar cells, photovoltaic modules

*Shanghai Electric Solar Energy Co. Ltd (33.97% Bosch-owned)



BOSCH

Consumer Goods and Building Technology

Security Systems



Fire and burglar alarms, video surveillance systems, time management and access control systems, etc.

Thermotechnology



Heating units and boilers

Power Tools



Power tools for the building trade and industry; accessories, garden tools and measuring tools, etc.

Home Appliances*



cooling, laundry and cooking products; imported high-end kitchen appliances

*BSH Bosch and Siemens Hausgeraete GmbH (50% Bosch-owned)



BOSCH

Sourcing in Emerging Markets

Sourcing in emerging markets

- Increase of emerging markets from 3.2 to 8.3* bn EUR in 2015
- Expansion of purchasing activities

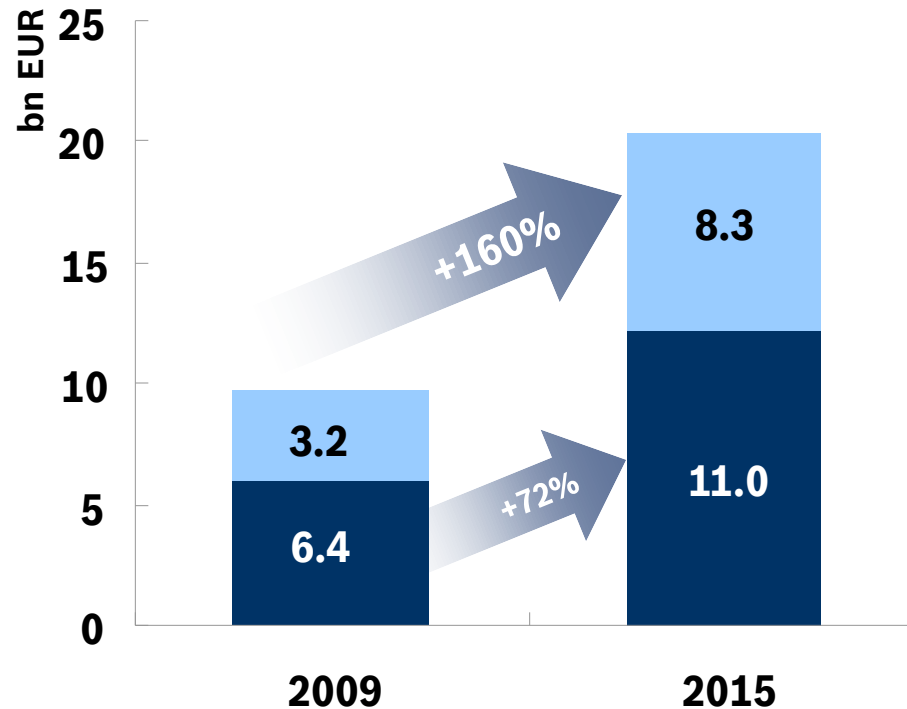

■ Emerging markets
■ Developed markets

*) direct materials



BOSCH

Challenges for China Sourcing

- High expectation of **quality** performance (e.g. zero defect principle)
- Great effort in **supplier qualification**: supplier enabling (e.g. coachings in quality process and tools)
- **Project management** skills
- Long **release process** in the automotive industry
- **Retention** of high potentials and skilled people



Premises for eCollaboration in China

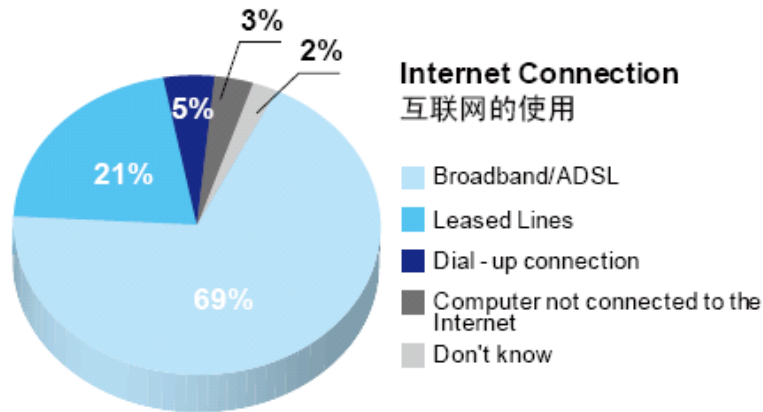

- Most companies have **ERP** systems in place
- **Internet** connection is no problem in China
- Most companies **do not** use electronic platforms like SupplyOn yet

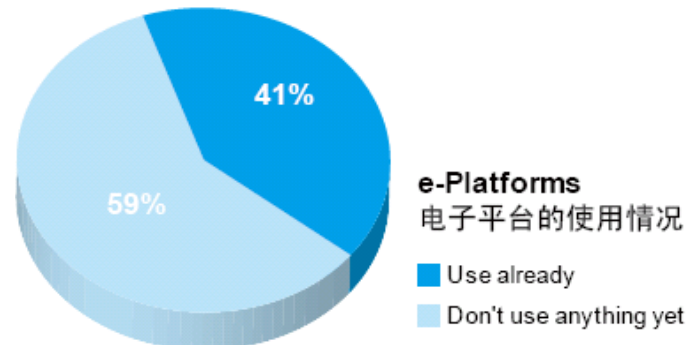
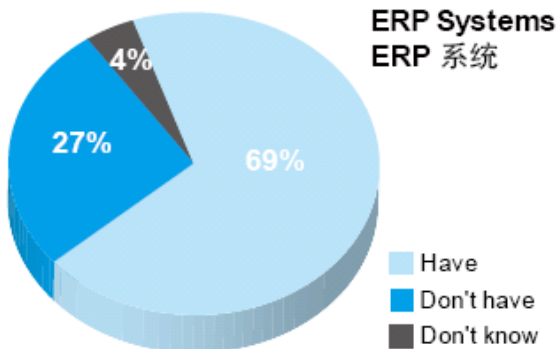

*Figures based on survey by China Supply Chain Council & SupplyOn in 2009

Premises for eCollaboration in China

Usage of e-Tools
电子工具的使用

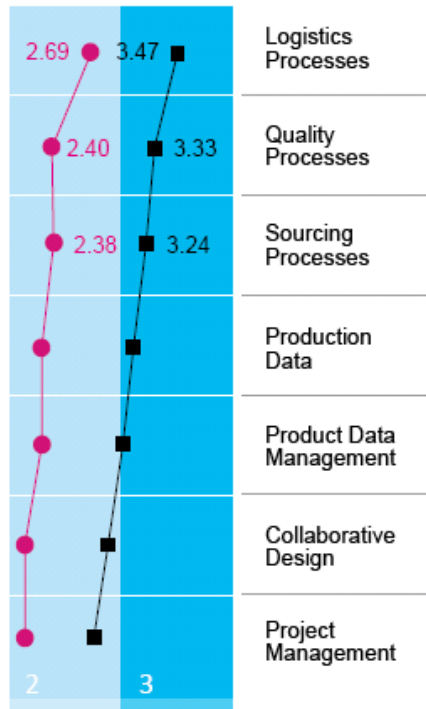

● Usage of e-Tools at the moment

■ Usage of e-Toc in three Years

Main areas of e-Tools application in China:

- E-Tools mainly used in **Logistics**, followed by **Quality** and **Purchasing**
- All areas show **strong growth** in the next three years

→ Importance of e-Tools will generally **grow** in the next three years in China

*Figures based on survey by China Supply Chain Council & SupplyOn in 2009



BOSCH

Impact of Supplier Type on eCollaboration

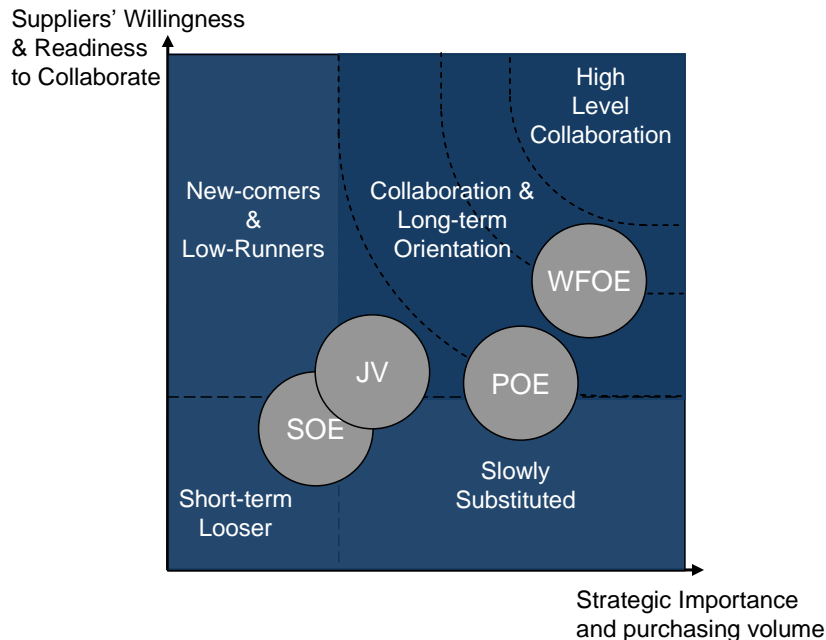

- Wholly foreign-owned enterprises (**WFOE**) show highest readiness to collaborate
- Privately-owned enterprises (**POE**) are strategically important but are not very familiar with collaboration yet
- Most State-owned enterprises (**SOE**) currently not ready yet.

Cultural Premises and Management Style affect Suppliers' Willingness to Collaborate



BOSCH

Lessons Learned for Supplier Integration

- Implement **web-based solutions** to minimize cost and avoid technical issues on the supplier-side
- Clearly explain **your goals and their benefits** of collaboration to the suppliers – individual explanations might be necessary
- Supplier's **mindset and strategic importance** as main supplier selection criteria
- Provide **trainings** on the process and the use of the eTools free-of-charge to your suppliers
- Carefully select the **service provider** and ensure it meets **local market requirements** (esp. language, service, and support)



Focal Points in Bosch Purchasing

Essential Success-factors (1)

Early involvement of Purchasing and Logistics in the Product Development

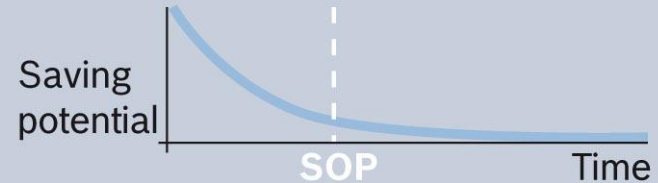

Bundling at Preferred Suppliers



Utilization of standardized processes und parts

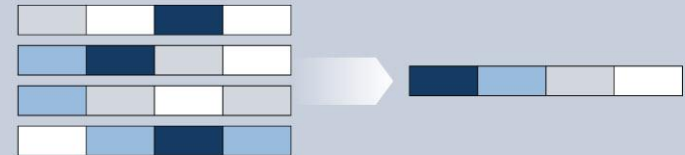

Worldwide Consideration (TCO – Total Cost of Ownership)



Focal Points in Bosch Purchasing

Essential
Success-
factors
(2)

Qualitymanagement
in Purchasing & Logistics



Efficient communication
via SupplyOn



Supply Risk Management



Employee development/
Competence management



BOSCH

SupplyOn at Bosch – Facts and Figures

- Usage of SupplyOn Services at Bosch **since 2001**
- Today **more than 3000 Bosch suppliers** use SupplyOn
- Number of connects **constantly increasing**

Connect Development Worldwide 2009 - 2011

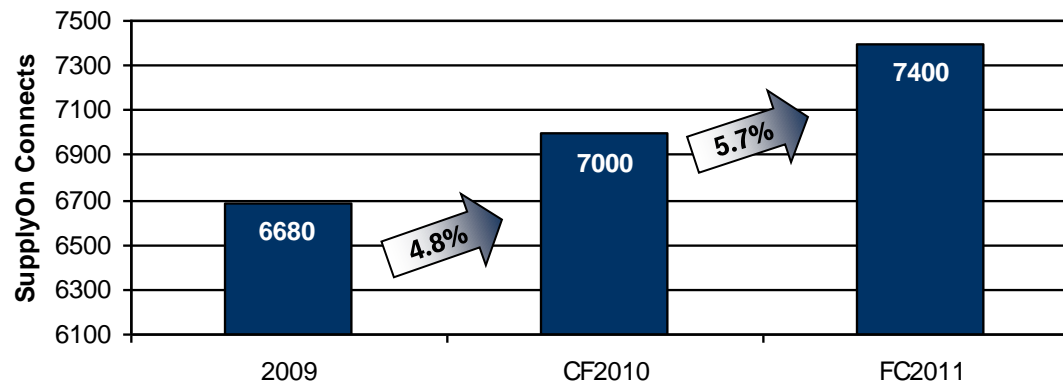

Bosch is continuously rolling out SupplyOn - worldwide



BOSCH

SupplyOn at Bosch China

Connects Development in China

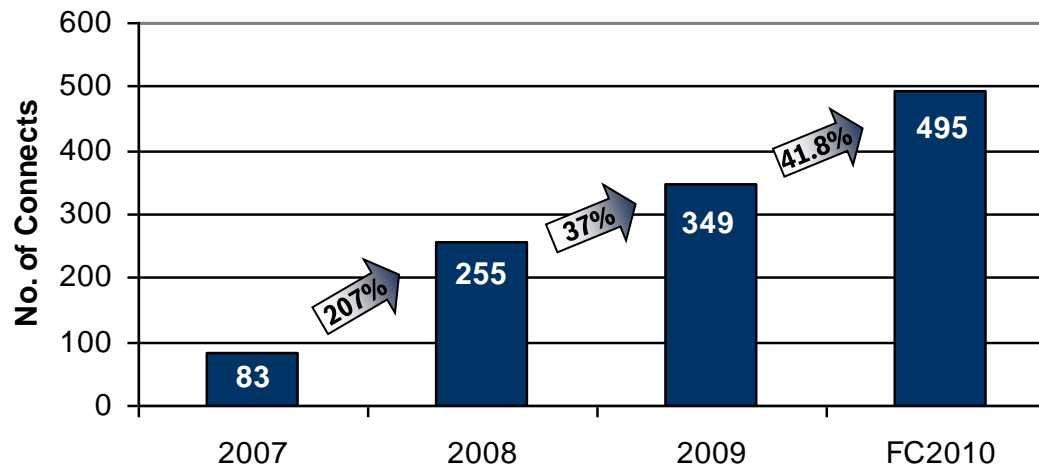

Continuous increase in number of connects since 2007



BOSCH

SupplyOn implementation steps

- **Start** of actual implementation
- Focus of **Purchasing and Logistics Processes**
- **Training** of suppliers and local staff

2008

- **Implementation (continued)**
- Expand to **Quality process**
- Expand to **Japan (WebEDI)**
- Increase **utilization**

2009



- Rollout **Sourcing Module** to **Japan**
- **Continued rollout** Sourcing, Quality and Logistic modules in **China**
- Increase **utilization**
- Rollout Sourcing module in **Thailand**
- Rollout Sourcing, Logistic models in **India**

2010ff

Implementation

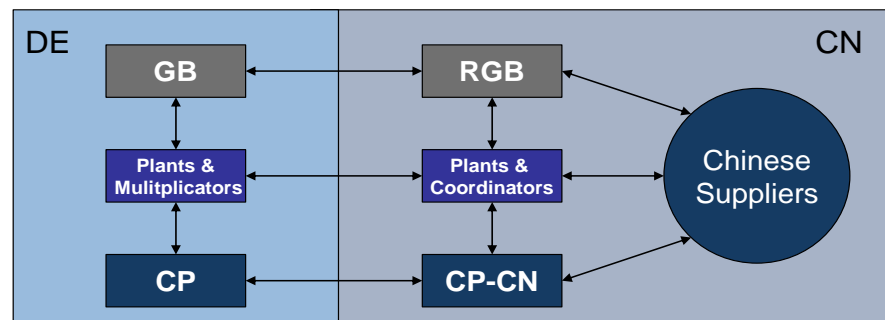

Continuous communication and collaboration as key-success-factor



BOSCH

SupplyOn Implementation in China

Bosch locations using SupplyOn as communication platform



- Locations with SupplyOn existing & planned:
Hangzhou, Changsha, Suzhou, Wuxi, Dalian, Shanghai, HK, Taipei, Beijing, Changzhou
- More than 200 suppliers connected
- Purchasing, Logistics and Quality modules implemented



BOSCH

Wrap-Up

- **Chinese market requirements** are different compared to the developed markets and have to be considered for the regional implementation
- Digital integration as a **competitive advantage**
- Selection of **service provider, top-management commitment, and supplier involvement** are key to success
- **Consistent usage** necessary to sustain benefits

Considering local requirements, significant benefit can be achieved with e-processes



BOSCH



BOSCH

博世 科技成就生活之美

*Thank you
for your attention!*

